

Project title Desk Study: Electrical weed control in Field Vegetables

Project number: FV 346

Project leader: John Reed, Silsoe Technology Ltd.

Report: Final report, November 2009

Key staff: Simon Miles

Location of project: Great Britain

Project coordinator: Peter Cornish,
Loveden Estates Ltd, Yorks

Date project commenced: 01/07/2009

Date project completed (or expected completion date): 31/10/2009

Key words: Weeds, electric weed control, organic, Field Vegetables

Whilst reports issued under the auspices of the HDC are prepared from the best available information, neither the authors nor the HDC can accept any responsibility for inaccuracy or liability for loss, damage or injury from the application of any concept or procedure discussed.

The contents of this publication are strictly private to HDC members. No part of this publication may be presented, copied or reproduced in any form or by any means without prior written permission of the Horticultural Development Company.

AUTHENTICATION

We declare that this work was done under our supervision according to the procedures described herein and that the report represents a true and accurate record of the results obtained.

[Name] John Reed
[Position] Technical Director
[Organisation] Silsoe technology Ltd

Signature Date

[Name]
[Position]
[Organisation]

Signature Date

Report authorised by:

[Name] John Reed
[Position] Technical Director
[Organisation] Silsoe Technology Ltd

Signature Date

[Name]
[Position]
[Organisation]

Signature Date

CONTENTS

	Page
Grower Summary	1
Headline	1
Background and expected deliverables	1
Summary of the project	1
Main conclusions	2
Financial benefits	3
Action points for growers	3
Main Section	4
Introduction	4
Methods	4
Discussion	4
<i>The basic principles</i>	4
<i>Killing weeds by electrical contact</i>	5
<i>Matching electrode height and geometry to the target</i>	6
<i>Electrical weed control factors, energy, power and performance</i>	8
<i>Electrical weeding safety</i>	9
<i>Target weed-crop combinations and the market</i>	12
<i>Selective electrical weeding</i>	12
Conclusions	14
Technology transfer	14
References	15

Grower Summary

Headline

Electrical weeding has potential as a niche alternative to chemical and mechanical control but there are no commercial electrical weeding machines available at present.

Background and expected deliverables

The concept of electric weed control is well established and relies on the application of a high voltage to growing plants, which causes rapid damage to cell structure and integrity leading to plant death. Prototype electrical treatment systems have previously been developed and evaluated in the UK, USA and Belgium to control weed beet in sugar beet, weeds that rise above the crop canopy or weeds that occur between crop rows.

There is currently an urgent need to find non-chemical alternatives for weed control given the ongoing reduction in herbicide options. The main aim of this project was therefore to carry out a desk study on electrical weed control systems in order to provide background information on the subject, ascertain the likely extent of applicability of the method to the industry and assess the potential health and safety implications of such systems.

The main deliverable of the project is to inform the industry of the current state of electrical weeding and provide pointers to its future potential as a non-chemical weed control technique.

Summary of the project

An extensive literature review has revealed that electrical weeding was a popular subject for research from the late 1970's to the early 1990's. A tractor-linkage-mounted machine was developed and sold commercially by Lasco's in the USA during this period, (Farm Show, 1981). The standard "Lightening Weeder" of 1981 had a 23 foot swath, required a tractor capable of developing a minimum 125 HP at the PTO and typically operated at speeds of 4 to 6 mph. UK sugar beet growers were particularly interested in the machine as a means of destroying weed beet in their crops. However, this interest and Lasco's machine disappeared with the advent of relatively low cost weed wipers which could do the same job at least as effectively.

If a suitable herbicide and application method is available for the control of weeds it will always out compete the electrical method from a cost and effectiveness point of view. However, given that the herbicide list is constantly being reduced the possibilities offered by alternatives such as electrical weeding need to be evaluated. The fact that approval for Glyphosate and its associated weed wiping application method is likely to be withdrawn means that electrical weeding could yet provide an important niche technique for future weed control in mainstream as well as organic farming.

Developing a practical and cost effective electrical weeder will present any prospective manufacturer with a range of challenging technical, safety and viability issues. As a prelude to embarking on a machine development programme it is therefore recommended that manufacturers should carefully establish what weed-crop combinations their machine would be capable of handling and whether the cost of development could be justified on the likely number of sales, i.e. establish the market. One of the most important targets would be the killing of volunteer potatoes in organic & main crop carrots and general organic crops such as beetroot, other targets are mentioned in the discussion.

A further priority for any potential manufacturer would be to ensure that their prospective machine would be able to meet the current health & safety standards. The health and safety executive (HSE) were closely involved in deciding the safety precautions needed to allow a UK research prototype to be built and tested in the field back in the 1980's, (Diprose, M.F. et al,1985). For this desk study the agricultural branch of the Health and Safety Executive were contacted, (HSE, 2009), and asked to comment on the contemporary safety implications associated with high voltage electrical weeding in the field. In summary, if the machine is equipped with the appropriate safety interlocks and guarding and complies with the requirements of the Machinery, Electrical Products and Electromagnetic Compatibility Directives then such a machine would be able to be used by suitable, trained UK farmers and contractors.

Comprehensive searches of patent and agricultural machinery databases indicates that commercially available electric weeding machines do not exist anywhere in the world. Should the UK develop a successful machine it is therefore likely that the market could be global.

In order to be commercially viable it is likely that any new machine should be capable of dealing with a broad range of weed types, sizes and positions relative to the crop. It is expected that the machine would also need to be adaptable re. electrode geometry and suitably equipped with control equipment to minimise power consumption. Power consumption to weed electrically is very high and increases as the number of weeds increase. Even at low weed densities (of the order 15 plants/m²) the technique requires twice the energy and is 5 times slower than chemical treatment and, like its mechanical counterpart, can require multiple passes, (Vigneault. C. et al, 1990). As weeds get smaller and therefore closer to the ground the technical challenges of controlling electrode height in order to make contact with the weeds yet prevent arcing to earth will need to be overcome.

The electrical weeding technique offers a number of advantages relative to more conventional methods. The technique would allow killing of inter-row windbreak crops yet protection would remain as plants wither. The advances in guided hoe technology could be exploited by deploying electrodes in place of conventional hoes or spray nozzles. Other benefits are mentioned in the main conclusions below.

The development of a commercial electrical weeder would provide an opportunity for a machinery company to create a new product and offer growers a useful extra tool they could use as some traditional methods become unavailable. However, overcoming the technical, financial and safety requirements of such a machine will require significant financial investment.

Main conclusions

- If a suitable herbicide and application method is available then it will always out-compete the electrical control method from a cost and effectiveness point of view.
- In the absence of herbicides electrical weeding could offer the industry a niche solution to control weeds in a range of mainstream and organic farming applications.
- There are no commercial electrical weeding machines available at present.
- If a product complies with all the relevant safety requirements and is in fact 'safe', properly CE marked, accompanied by operator instructions to ensure safe use and that it is a machine "for use in agriculture" then the machine could be operated by anyone in that

industry. The manufacturer would need to specify that training is required and it is the duty of the user to undertake this.

- Assuming the time required to kill a plant is 0.2 s and using an effective electrode width of 0.4 m results in a typical forward speed of 2 m/s. For a 6 m wide machine this translates into a theoretical work rate of 43200 m²/h or 4.3 ha/h (ignoring power constraints).
- Electric weeding is a high energy technique that is best suited to low weed densities. Assuming 1.76 kJ of energy is required to kill a plant and 50 kW is continuously available at the electrode this equates to a killing rate of 28.4 weeds/s. To achieve 4.3 ha/h (12 m²/s) the maximum weed density would therefore need to be less than 2.4 weeds/m². Higher weed densities would require proportionately more power.
- To date electric weeding has only proven to be fully effective, in one pass, in low density weed situations such as crop bolters in sugar beet (0.5 – 0.6 plants/m²). With weed wiping expected to lose its approval the electric method could find a place as a replacement for the weed wiper. The development of an electric weed wiper for low density weeding is therefore seen as the most likely commercial application of the technique in the short term.
- Compilation of a list of the priority target weed–vegetable crop combinations by agronomists' is required.
- Building an instrumented rig and testing it in the field on a range of weed types and vegetable weed-crop combinations (from the agronomist's list) would fill in most of the knowledge gaps and provide key information on the broader applicability of the technique.
- Electrical weeding offers a number of advantages over conventional methods e.g. timeliness (could work after rain and in bad soil conditions when hoes would be inappropriate), does not disturb soil, lower cost than hand weeding, no toxic residue, no soil retention issues, not wind effected.

Financial benefits

The cost of electrical weeding is claimed to be 10% of that for hand weeding, (Balls, R., 2009).

The financial benefits of electrical weeding to the industry would accrue as a result of the technique being available as an alternative to herbicide, hand or mechanical treatments. Collection and assimilation of the agronomic data required to calculate the value of these benefits is out of the scope of this technical review.

Action points for growers

If growers wish to see the development and introduction of electrical weeders then they will need to lobby potential funding bodies such as the HDC, Defra and the Technology Strategy Board (TSB) to provide support for:

- A survey to estimate the potential market size and value for electric weeding.
- A contribution towards the cost of developing a technology demonstrator.

Main Section

Introduction

The continuing reduction in herbicides from the approved list is causing concern amongst growers since it has the potential to reduce crop yields, quality and, ultimately, the commercial viability of some crops. The HDC is therefore keen, on behalf of the growers, to explore any non-chemical alternatives that may offer a practical means of weed control. Killing weeds by electric shock is an old technique (viz. patent US3919806, 1975) that found its way into main stream agriculture in the USA for a period in the 1980's. However, the relatively low cost and energy requirements associated with chemical based weeding proved to be the undoing of the electrical technique and the manufacturers ceased production. In view of the changes being brought about by environmental issues the HDC decided to commission this desk study to investigate whether electric weeding could yet emerge as a serious and practical method of weed control for vegetable growers.

The overall aims of the study are to review the topic of electrical weeding in order to provide background information on the subject, to ascertain the likely extent of applicability of the method to the industry and to assess the potential health and safety implications of such systems.

The specific objectives of the study are:

1. Provide background information on electrical weed control systems and published research,
2. Establish the opinion of the Health and Safety Executive on the methods and their likelihood of approval.
3. Ascertain if any equipment is available in the world.
4. Consider the likely extent of the applicability of the method to the industry.

Methods

The information needed to carry out the study was gathered using internet and library searches of journals and publications; patent database searches; internet searches of equipment and systems suppliers; e-mail, telephone discussions and interviews with experts. Over 60 references were reviewed in order to scope the background of the subject for this report. Those directly referred to in the report are listed in the references section.

Discussion

The basic principles

Applying high voltage electricity to growing plants causes rapid damage to the cell structure and integrity leading to plant death. Two basic methods have traditionally been used to kill weeds with electricity viz. non-contact-very-high-voltage (typically 30kV to 50 kV) and contact-high-voltage (typically 5kV to 15 kV).

The voltage in the non-contact method is so high it causes a spark to discharge between the electrode and plant. The Russians carried out research in this area in the early 1970's. In

the (Diprose. M.F., Benson, F.A., 1984) review paper they report in their introduction that: Slesarev applied 25kV, 10^{-6} s duration pulses to White Mary plants 30 – 40 mm tall. Death was reported after 3 days when all respiration, transpiration and photosynthesis were recorded as zero. Raising the pulse voltage from 30 kV to 50 kV in separate Slesarev trials increased the lethal effect, although Slesarev does not give details. Svitalka and Klimov are quoted respectively in the review as having successfully tested a model of a spark beet thinning machine and report on a machine employing spark discharges across the stalks of sunflower plants near the roots. These discharges were applied before harvesting to accelerate the ripening and drying of seeds. No further information was supplied about the performance or details of either of the machines.

The Russian approach was not followed by U.S. or European researchers due to the high cost and practicalities of generating such extreme voltages, (Diprose. M.F. et al, 1978; Diprose. M.F., Benson, F.A., 1984). Western researchers chose to pursue the contact method which requires the electrode to come into contact with the plant or weed in order to complete the electrical circuit through to a ground penetrating coulter. This study concentrates on the contact method since this approach has most chance of being utilised in a practical farmers machine, at least for the foreseeable future.

Killing weeds by electrical contact

Patents going back to the 19th century have been granted for machines that claimed to kill weeds by electricity. However, it was not until the 1970's, when the Lasco company of Vicksburg, Mississippi took out a raft of patents, that the principles were put into practise and a commercial machine was produced.

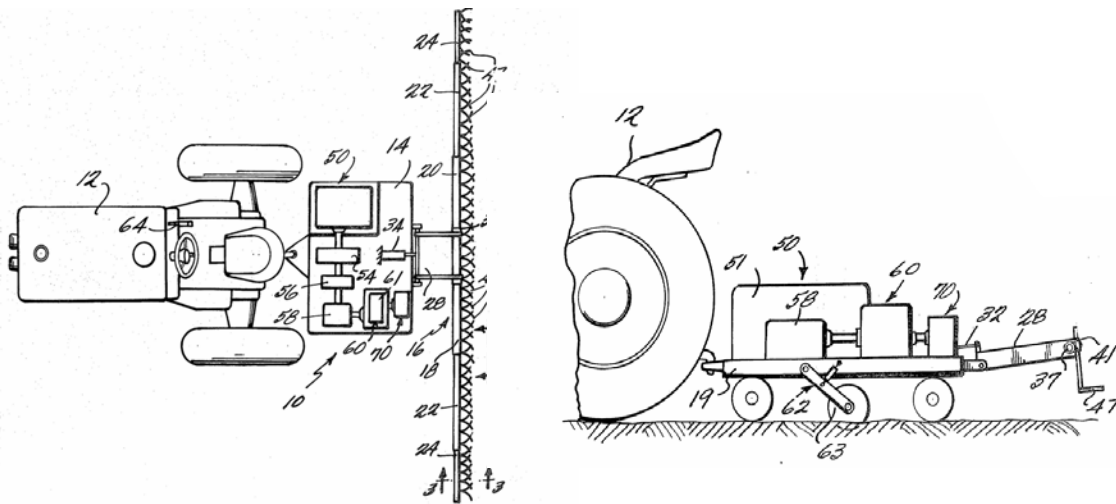

Fig. 1 Illustrations from one of Lasco's early patents, US 3919806 filed in 1974

The illustrations in Fig. 1 show the basic parts of an electric weeder. Power is produced from an AC generator (50) and transformed (60) up to approximately 10kV. The voltage is then applied to a boom (18) and then to individual electrodes (47). The electrical circuit is completed via any plant that contacts electrode (47) and "a conductive wheel (63) having a sharpened edge which penetrates into the ground several inches and grounds the whole electrical assembly". Lasco's machines, using their Electrical Discharge System (EDS), were successfully used in a wide variety of field crops and conditions according to Lasco's president W. Dykes in 1981. The machines were also extensively used as tools for research in the US and Europe.

Matching electrode height and geometry to the target

It is important to match the electrode geometry to the crop and target weeds. For obvious reasons it is usually undesirable for the electrode to come into contact with the crop. The weeds therefore have to be distinct from the crop in some way i.e. taller or spatially separated between rows. Lasco's realised that complete isolation of the crop was not always a requirement and took out a patent, (US4094095, 1978), to cover the selective control (electrocution) of plants based on differential tolerance to electric shock, see Fig. 2.

The illustrations in Fig. 2 show details of a spring back electrode. The electrodes are mounted horizontally and overlap at their tips (44). They are sprung mounted about a pivot at their forward ends (38). In this design the spring members have a spring constant such that the relatively stiff crop plants (in Lasco's case, sycamore trees) will deflect the spring members while the relatively flexible weeds (common cocklebur) will not. The geometry of the tips (44) means that the crop quickly deflects the rods so the time in contact with the electrode's is minimal. However weeds between the rows spend a relatively long time in contact with the main part of the electrode (42) as they slide by and therefore receive a lethal dose, quote "the difference in dwell times of contact combined with the generally greater resistance of the crop plants to electrical energy destruction than the weeds, results in the destruction of one but not the other".

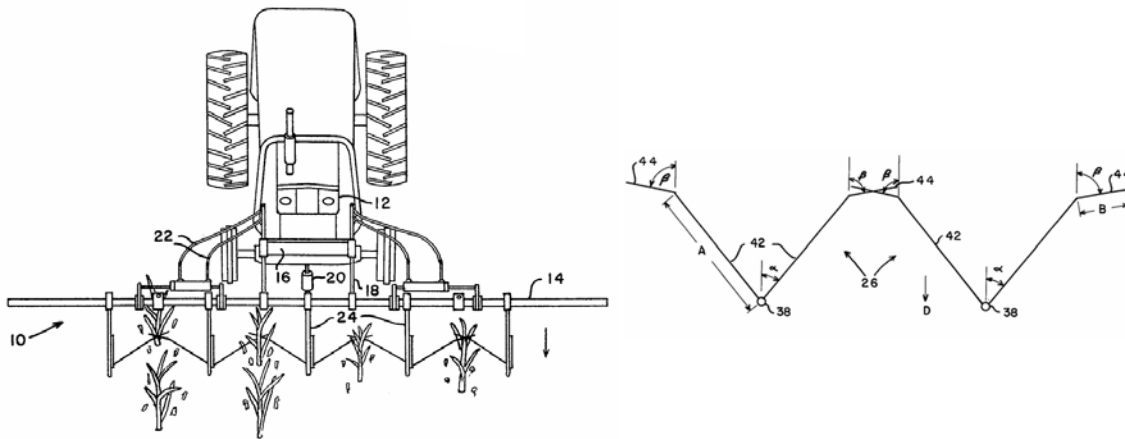

Fig. 2 Illustrations from Lasco's patent, US4094095(1978)

In the embodiment shown in Fig. 2 the horizontal mounting bar (14) is also energised but it is connected to a higher voltage source (15 to 30 kV) than the spring members (5 to 10 kV) because the taller weeds that will be contacted generally require a larger input of electrical energy to be destroyed than the plants contacted by the spring members.

The importance of dwell time, i.e. time in contact with the electrode, is a parameter that has been the subject of much research since and in conjunction with the applied voltage, it has a direct influence on plant mortality. Dwell time was one of the factors researched by Diprose, M.F. et al (1978) that dictated the design of electrode used by them on their sugar beet bolter machine in the early 1980's.

Their machine incorporated a 6m wide electrode that consisted of a 3 m centre section and 1.5 m wings at each end. The electrode was constructed from three 25 mm diameter mild steel tubes, mounted behind each other and 150 mm apart. The electrode was mounted on the front of a tractor with the generator at the rear. The electrode was lowered to the point where it remained clear of the crop yet was low enough to contact the bolters. As the machine moved forwards (approximately 5 kph) the electrode contacted the plant and

pushed it down as the machine passed. The reason for fitting three tubes was to ensure that weeds stayed in contact with the electrode for long enough (approximately 250 ms) when travelling at 5 kph. Using one tube would result in the plant springing back too early and only receiving a fraction of the energy.

Referring to Fig.3, bushy plants contact may begin before the leading edge of the electrode is over the plant base and cease after the trailing edge of the electrode has passed the plant base, (Vigneault. C et al, 1990). The 'effective width of the electrode' (W_{eff}) which is the distance travelled while maintaining contact with the plant will always be greater than the actual electrode width and is a function of electrode width and height, plant geometry and plant rigidity.

Using the electrode geometry referred to above i.e. 3 bars, 150 mm apart, the distance from the front to the rear of the electrodes is 325 mm. Allowing another 75 mm for plant bend gives an effective electrode width of nominally 400 mm. From elsewhere in the report if we require approximately 0.2 s of contact time to kill the plant then the required forward speed would need to be 2 m/s or 7.6 kph. This equates to a work rate of 2 m/s x 6 m x 3600 s = 43200 m²/h or 4.3 ha/h.

The number of plants in contact with the electrode at any one time (n_c) is the product of electrode length, effective width (W_{eff}) and population density (D).

$$n_c = L W_{eff} D \quad (1)$$

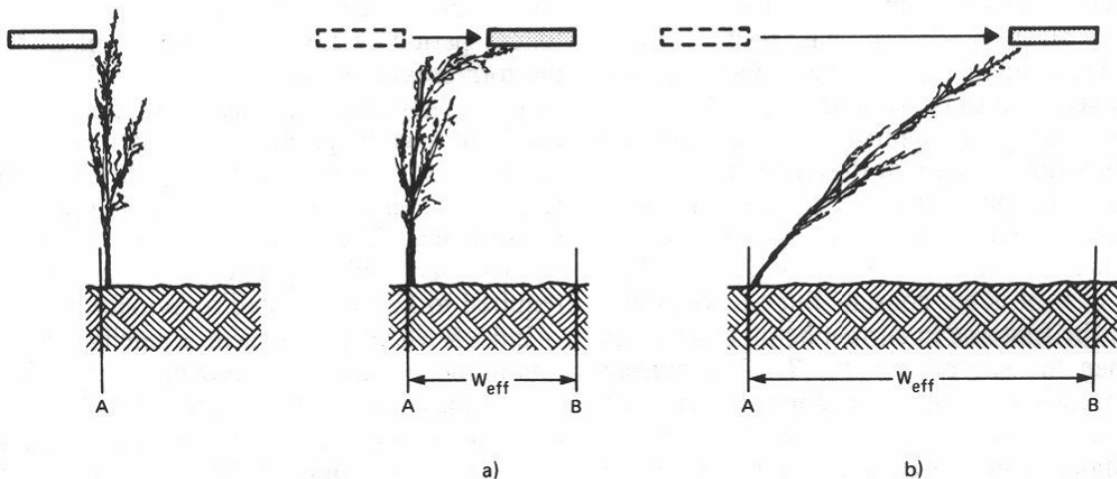

Fig. 3. Diagram showing theoretical minimum (a) and maximum (b) contact distance as a function of plant and electrode height and electrode width, A = beginning of contact, B = end of contact, W_{eff} = effective width.

The power needed to weed electrically is highly dependent on the number of weeds in contact with the electrode (n_c), this is discussed in the next section. For a constant electrode height, tall plants will remain in contact with the electrode for a longer period of time than shorter plants and the former will absorb more energy. To ensure that shorter plants are killed, sufficient energy per plant must be provided by either increasing the voltage or lowering the electrode height, resulting in an excess energy being provided to tall plants.

For weeds in the row their height must exceed that of the crop before electrocution can be used. In theory a 50 mm to 100 mm height difference is needed. In the field a minimum

height differential of 100 mm to 200 mm is required for adequate weed control and minimal crop damage.

Once their patents were in place Lasco's went on to produce a machine for sale. The president of the company Willis G Dykes subsequently presented a paper, Dykes. W.G. (1980), at the summer meeting of the American Society of Engineers describing the principles and practises of electrical weed control. The relative effect of the key parameters that dictate electrical weeding performance that were researched are discussed further in the next section.

Electrical weed control factors, energy, power and performance

The key parameter that effect the performance of an electrical weeder and its ability to kill weeds are available power, applied voltage, dwell time, weed type (energy to kill) and weed density. Other practical requirements are that the weeds need to be spatially separated from the crop either by being taller or by being between rows and that they are large enough that the electrode does not short to earth in undulating ground conditions e.g. seedbed situations. Dwell time was covered in the previous section. This section will discuss the other key parameters.

The amount of power (P) needed to electrocute weeds is a function of the voltage (V) and the load resistance (R_1). From Vigneault. C. (2002), neglecting the transformer resistance and assuming an ideal case where all weeds have the same resistance, the load resistance becomes a function of the plant resistance R_p , the number of weeds in contact with the electrode (n_c), see equation 1, and the soil resistance (R_s), the power is:

$$P = V^2/R_1 = V^2/((R_p/n_c) + R_s) \quad (2)$$

The number of weeds in contact with the electrode is proportional to the weed population density. As the weed density increases the number of weeds touching the electrode increases and consequently the power requirement also increases according to Equation (2). In addition, as the weed density increases the plant resistance becomes negligible compared to the soil resistance as indicated by Eq. (2). Therefore a very high weed density increases the power but most of the energy is absorbed by the soil.

The relationship between voltage applied and treatment time is not linear. For every doubling of voltage there is a fourfold decrease in required treatment time.

A typical field without prior weed control has a weed density ranging from 50 to 2000 plants/m². A weed control study on a field having a weed density of 200 plants/m², (Vigneault. C et al, 1990), showed that electrocution required approximately 20 times more energy and 50 times longer to apply than spraying herbicide. For fields with a weed density of 15 plants/m² electrocution still required twice the energy and took 5 times longer than chemical weed control. Similar to mechanical weed control, electrocution requires two or three treatments to achieve the desired effect when compared to a single application of herbicide. Vigoureux. A. (1981) obtained 98 to 99.9% control of bolting sugar beet using 8 to 15 kV rms, and 50 kW when weed densities were 100 to 5000 stem/ha. For weed populations with more than 18000 stem/ha only 24% control was obtained. For populations up to 2000 stem/ha, one treatment would be sufficient for adequate control. However, at least two treatments were needed for populations between 2000 and 6000 stems/ha. At higher densities the generator power was insufficient to kill all weeds in one pass.

Some plants are more susceptible to electrocution than others and all plants require more energy to produce a lethal response as they mature, (Dykes. W.G., 1980). In his experiments he found an 8 to 10 fold increase in killing energy e.g. Hemp Sesbania, 0.25 kJ

at 2 kV to 2 kJ at 5kV, was required in three species while maturing from 3 to 5 weeks. Vigneault. C et al (1990), quotes an overall average of 1.76 kJ to kill weeds late in the growing season. He calculated that for an 80kW tractor with a 50 kW generator operating in a field with a plant population density of 200 plants/m² and supplying 1.76 kJ/plant, the full operating capacity of the weeder would only be 0.05 ha/h not counting time for headlands! The extent to which roots are damaged depends on the size and shape of roots, soil type and moisture conditions reports Diprose. M.F., Benson, F.A. (1984). Bulbous roots such as those of weed beet tend to be damaged as the current flows through a substantial part of the tissue before leaving the root. The drier the soil the more damage to the root and the deeper the damage. Plants such as couch grass with an extensive underground rooting system are generally not killed.

Vigneault concludes in his 'Weed Electrocutation' section of the Encyclopaedia of Pest Management, Vigneault. C. (2002), that "Weed electrocutation cannot be used as a primary weed control method, because it comes cost effective only in areas with low weed density. With the high cost of application, it can be used in areas where chemical treatment is not acceptable, or in areas where there is a high risk of soil erosion."

A series of 10 field experiments were carried out in July 1979 to assess and compare the energy and economics associated with one of Lasco's EDS weeders, a roller herbicide applicator and a recirculating sprayer, (Kaufman. K.R., Schaffner. L.W., 1982). The EDS weeder changed from being the most costly to the least costly method as its annual usage increased. The EDS weeder needed to be used on about 210 ha/year to equal the same hectare cost as the roller applicator and on about 920 ha/year to equal the same per hectare cost as the recirculating sprayer.

Electrical weeding safety

Any commercially produced electrical weeder will need to be 'safe' from an operator and bystander's point of view. The health and safety executive (HSE) were closely involved in deciding the safety precautions needed to allow the Diprose, M.F. et al (1985) research prototype to be built and tested in the field. For this desk study the agricultural branch of the Health and Safety Executive were contacted, HSE (2009), and asked to comment on the contemporary safety implications associated with high voltage electrical weeding in the field. Their initial feedback was that;

'In essence the comments in the Diprose, M.F. et al (1985) paper still stand. Additionally any commercial machine would need to comply with requirements in the Machinery, Electrical Products and Electromagnetic Compatibility Directives which have come into force since the paper was written'.

It would be the duty of any prospective manufacturer to ensure that their machine complies with the relevant parts of all the above directives. However, in order to home-in on the relevant parts of the directives the HSE were asked if they could further elucidate. Remembering that it is the manufacturers' responsibility to comply etc. the HSE offered the following further guidance:

'If the product complies with all the relevant safety requirements and is in fact 'safe' and properly CE marked then HSE would have no real concerns about such machines'.

1. Machinery Directive 2006/42
http://eurlex.europa.eu/LexUriServ/site/en/oj/2006/l_157/l_15720060609en00240086.pdf see specifically Article 1 and part 1.5.1 of the EHSRs - there are some CENELEC standards which might apply - EN60204 parts 1 and 11 for example - I

don't have the standards but you may get some info from the BSI website as to their scope and application.

2. Directive 72/23 was repealed by 2006/95 <http://eur-lex.europa.eu/LexUriServ/LexUriServ.do?uri=OJ:L:2006:374:0010:01:EN:HTML> - general principles in annex 1 will apply
3. Electromagnetic compatibility Directive 2004/108 - <http://eur-lex.europa.eu/LexUriServ/LexUriServ.do?uri=CELEX:32004L0108:EN:HTML> – Manufacturers would need to check the scope in Articles 1&2. If there are any harmonised standards you may find them at <http://www.newapproach.org/Directives/DirectiveList.asp>

It was felt important to have clarified whether it would be reasonable to assume that electrical weeders could be operated by a farmer rather than it being purely a contractor's tool. In the 1985 paper the view taken was that the machine would need to be controlled by a specialist contractor who would be responsible for the training of his operators in the dangers of electricity, appropriate systems of work to counter danger and in emergency procedures. The HSE feedback to this query was:

'The presumption of conformity means that it is offered for sale 'as is' - e.g. with relevant safeguards and accompanied by operator instructions to ensure safe use. I think you need to assume that this is a machine 'for use in agriculture' and therefore could be operated by anyone in that industry. That does not mean you cannot specify that training is required and the duty is on the user to undertake this.

A company could voluntarily restrict sales to specific users but there is no real legal basis for this - and generally little control over the used market - to do this I think the manufacturer would have to retain ownership e.g. through lease/hire'.

Farmer feedback suggests that the leaseback approach would be difficult to implement in our industry.

The Diprose, M.F. et al (1985) research machine incorporated a rear mounted PTO driven generator and transformer and a front mounted electrode system. The following list of safety measures and comments have been extracted from the Diprose, M.F. et al (1985) paper:

1. The electrodes should be guarded where guards do not interfere with the function of the machine.
2. The electrical apparatus should be fully enclosed in metal work bonded to the frame of the tractor or in suitable insulating material.
3. An isolating switch should be provided accessible at the rear of the machine.
4. Emergency push buttons should be located on either side of the rear generator housing.
5. Danger notices should be fixed to the machine and should be placed in prominent positions in the field when the machine is used.
6. The start/stop buttons should be located in the cab.
7. A driver's seat switch should be provided to de-energize the generator output to the high-voltage system where the driver is not in position.
8. A key switch should be located in the cab to prevent the generation of high voltages by unauthorized persons.
9. A flashing lamp should be located on the roof of the cab to give a warning of high-voltage operations.
10. * An isolating switch should be provided within the driver's cab.

* The original purpose of an additional power isolating switch in the cab was to ensure that no matter what happened to the control apparatus in any emergency the driver would be able completely to de-energize the high-voltage supply from the cab. It was

subsequently agreed that this could be equally effectively achieved by tripping the power take off.

All the precautions which were agreed were carried out satisfactorily but the guarding specifications presented the most difficulty. Since the electrodes operated at a variable height it was impossible to obtain adequate clearance from the front by means of the top physical barrier but a good degree of protection was provided at the sides and at the rear of the electrodes. In spite of the provision of the safety measures described above the safe use of the apparatus would be dependent upon the system of work and a properly trained operator.

The Lasco machines were sold to and operated by farmers. The Farm Show (1981) article on Lasco's weeder reports: several safety interlocks, incorporated into the high voltage machine, must all be satisfied to make it operate. For example the machine won't run if the operator isn't in the seat, if the machine loses its electrical ground connection or its forward motion. Dykes, Lasco's president said, "*these patented safety features, along with operator training and supervision, help ensure safety for both operators and bystanders. We've never had a bad experience with electric shock, nor have we ever had a problem with dry crops catching fire in the field*". The reference to the precautions re the machine loosing its ground connection and only working if the machine is moving are stated in Lasco's patent, US3919806 (1975). The importance of the cutting of the power when the earthing coupler lifts out is particularly significant since the return path would otherwise be through the tractor tyres!

Additional comments on the 1985 research machine safety measures were asked of the Association of Manufacturers of Power Generating systems.

Feedback 1 was:

Their point 9, I would have thought is not adequate. Tractors have flashing lights on the cab for warning other than "high voltage". The machine itself in my view should carry the high voltage warning light, perhaps in the form of the usual high voltage symbol of a lightning flash.

Their point 10 is valid, and I think it is not reasonable to say that switching off the power drive is an effective means of electrically de-energising. I see this as akin to stopping a diesel engine on a generating set to electrically de-energise circuits, there is mechanical inertia in the system (mainly the generator) and isolation should be on the prime feature that is being isolated, not by a secondary means.

Their point 7 is a good idea but in conjunction with their point 10, it must be possible for the driver to isolate even if he is in the seat, e.g. if he sees someone at risk from the machine when he is in the cab.

Feedback 2 was:

In the Diprose, M.F. et al (1985) paper the safety aspects were, quite rightly, associated with the Health and Safety at Work act etc. – but of equal relevance is the 1989 Electricity at Work Regulations. The EAWR basically says that a person (or duty holder) is guilty until proven innocent. It's for the designer / operator to prove they have taken all reasonable precautions as regards protection to property life and limb.

I think the comments made by HSE are all very sensible. With regard to emergency stops (EM), it should not be possible to go from a tripped state to a running state in one operation. EM Stops should be mushroom headed stay-put type. After operation of EM stop and the plant is ready to be returned to service, the routine should be to release the EM stop and then perform a separate re-set operation by means of a pushbutton or key switch. Releasing of the EM stop alone should not re-energise the plant.

Section 11-13 talks about safety being dependant upon the awareness and skill of the driver. I wouldn't be comfortable with this. In Industry, generally, it's not sufficient just for the operator to be careful. May be it might be possible to fit proximity / motion sensors to the casing around the electrodes such that if people or small animals approach the electrodes are de-energized. Maybe the metal work around the electrodes could be charged up in the same way as a cattle fence. The cattle fence uses the principle of limitation of discharge of energy to keep animals away, this is quite acceptable under BS7671 (IEE Wiring Regs). The effects of the cattle fence are not pleasant to Humans – but not fatal. In other words use the cattle fence principle with its lower voltage pulse (with virtually no current) to keep persons away from the greater danger i.e. the HV Electrodes.

Summarising, from the HSE's and other feedback the indication is that a properly safeguarded and interlocked machine that complied with all the appropriate directives and standards could be operated by farmers. The authors would advise any prospective manufacturer to thoroughly scrutinise the directives and advice referred to above to ensure that building a machine of this type could indeed comply with the appropriate directives!

Target weed-crop combinations and the market

Before embarking on expensive machine developments we would recommend that manufacturers should carefully establish what weed-crop combinations their machine would be capable of handling and whether the cost of development could be justified on the likely number of sales, i.e. establish the market. With the expected demise of glyphosate one of the original targets for electrical weeding, control of bolting sugar beet, again becomes an attractive prospect since the plant densities are typically low (0.5 – 0.6 plants/m² for one pass success). However, given that this is a review for the vegetable sector, one of the most important targets would be the killing of volunteer potatoes in organic & main crop carrots and general organic crops such as beetroot. Other targets mentioned in discussions with consultants include killing mugwort in parsnips, turnips, swedes, ragwort in grassland, volunteer potatoes in vining peas, killing thistles in multi-pass operations (causes thistles to multi shoot) and killing seedbed weeds after sowing and before crop emergence e.g. carrots (assuming electrical weeders could be developed to deal with small weeds in close proximity to the surface).

As mentioned in the section on power and performance some weeds are more susceptible to destruction by electrocution than others e.g. weed beet versus couch grass. Compiling a detailed list of potential weed-crop combinations is an agronomic task beyond the scope of this review. It will require practical trials and agronomist involvement to establish the efficacy of the technique for different species, e.g. doc control in organics, however, it is a task that ought to be undertaken in order to provide an indication of the scope for electrical weeding. The list should ideally provide information on expected weed densities and size etc. since further developments will be required in electrical weeding to cope with medium to high weed densities. Building an instrumented rig and testing it in the field on a range of weed types would fill in most of the knowledge gaps and provide key information on the potential efficacy of the technique.

Selective electrical weeding

Rapid advances have been made in robotics, control and electronics over the last 2 decades and the cost of these technologies has dropped. It is therefore not surprising that researchers have begun to investigate the possibilities of robotic weeding.

In the mid-nineties an EU research programme on the reduction of chemical weed killers in agriculture resulted in the production of a prototype electric weeder for selective control of

small weeds (smaller than 10 cm^2), (Blasco, J, 2002). This machine involved the collaboration of an international group of scientists who investigated the detection of weeds by machine vision and high speed control of a robotic arm to position an electrode onto individual weed targets. The end-effector (robot tool) was equipped with an electrode powered by a set of batteries which killed the weeds by producing an electrical discharge of 15kV, see Fig. 4.



Fig. 4. Selective electric weeding using a mobile robot.

The machine was tested in Spain in a conventional lettuce field with an average weed density was 8 weeds/m^2 . The weeder was pulled by a conventional tractor at 0.8 kph. The time for treating each weed had to be less than 1s (including 0.2s for electrical discharge). The electrode eliminated 100% of small weeds (less than 5 leaves or less than 200 mm tall). No significant damage was caused to lettuces having more than ten leaves.

Although slow this device showed that selective electrical weeding is technically achievable. Most of the problems the researchers encountered were associated with the twin vision systems (one for weed positioning and one for vehicle positioning) that were needed in order to cope with the continuous motion caused by being towed with a tractor. Correspondence with one of the authors indicates that he thought the idea would be best used in conjunction with an autonomous robot platform that would stop to weed then move to the next patch. The device could then be left to weed the field independently.

More recently, research has been published on the possibility of using laser treatment as an alternative weed control method to herbicides, Mathiaassen, S.K. et al (2006). This research is in its infancy, the investigation concentrates on directing lasers accurately onto the apical meristems of selected weed species at the cotyledon stage. Two types of continuous wave diode lasers were used, 532 nm and 810 nm, and two spot sizes for each, 0.9 mm/1.8 mm and 1.2 mm/ 2.4 mm at ranges (focal length) from the plant of 11 mm, 20 mm and 30 mm. The lasers were targeted by hand on small seedlings. The researchers conclude that laser

exposure of the apical meristems of weed species can be used as a method of physical weed control. The highest efficacy was obtained using the 5 W, 532 nm laser and 1.8 mm spot diameter. Chickweed and scentless mayweed were much more susceptible to the technique than oilseed rape. The practical application of this technique is a long way off and the authors conclude that in order to improve the performance of the technique and document the efficacy of the technique on a broader range of weed species, more powerful lasers and further research and development is needed.

The technique may have potential at least for the control of small emerging weeds, however, deployment in the field will be fraught with difficulties, not least the targeting of lasers with longer focal lengths on the most susceptible parts of the weed. For the foreseeable future electrocution provides a more practical approach to weed control than laser treatment.

Conclusions

If a suitable herbicide and application method is available then it will always out-compete the electrical control methods from a cost and effectiveness point of view.

In the absence of herbicides electrical weeding could offer the industry a niche solution to control weeds in a range of mainstream and organic farming applications.

There are no commercial electrical weeding machines available at present.

If the product complies with all the relevant safety requirements and is in fact 'safe', properly CE marked, accompanied by operator instructions to ensure safe use and that it is a machine "for use in agriculture" then the machine could be operated by anyone in the industry. The manufacturer would need to specify that training is required and it is the duty of the user to undertake this.

An agronomic study of the crop area and weed crop combinations that are likely to be amenable to electric weeding is recommended (in order to provide potential manufacturers with key data on likely market size and weed-crop morphology needed to justify the development of appropriate machinery).

Electrical weeding is very energy intensive compared to mechanical or chemical control methods. The power (energy) required to control weeds electrically rises in proportion to the number of weeds. Methods of limiting the power usage to avoid overkill (applying energy beyond that necessary to destroy the plant) will need to be incorporated if electrical weeding is to be used in anything other than low weed densities.

Selective weed control by deployment of individually targeted electrodes using robotics is technically feasible. Developing it commercially would be best done in parallel with its use on an autonomous vehicle.

For the foreseeable future electrocution provides a more practical approach to weed control than laser treatment.

Pre-crop emergence control of small weeds on seed beds remains a technical challenge due to the close proximity of the ground and the electrode(s).

Technology transfer

As a first stage to exploiting the possibilities of electrical weeding we recommend that an electric weed wiper be developed and, in parallel, an agronomic review be undertaken to

identify appropriate vegetable weed-crop combination that could be treated by such a machine e.g. volunteer potatoes in carrots.

Electrical weeding performance could be enhanced and the breadth of applications increased by accurate guidance of the electrodes. Integrating vision guided hoe technology with electrical weeding would broaden the market scope for both technologies.

References

Balls, R., (2009) Sustainable weed control technologies in high value crops an innovation workshop. Warwick HRI 23 June 2009

Blasco. J., Aleixos. N., Roger. J.M., Rabatel. G., Molto. E. (2002). Robotic Weed Control using Machine Vision. *Biosystems Engineering*. 83(2):149-157.

Diprose. M.F., Hackam. R., Benson, F.A. (1978). Weed Control by High Voltage Shocks. *Proceedings 1978 British Crop Protection Conference*. 443-450.

Diprose. M.F., Benson, F.A. (1984). Electrical methods of killing plants. *Journal of Agricultural Engineering Research*. 30:197-209.

Diprose, M.F., Fletcher, R., Longden, P.C., Champion, M.J. (1985). Use of electricity to control bolters in sugar beet (*Beta vulgaris* L.): a comparison of the electrothermal with chemical and mechanical cutting methods. *Weed Research* 25:53-60.

Dykes. W.G. (1980). Principles and practises of electrical weed control. *Am. Soc. Agric. Eng., St Joseph, MI Paper 80-1007*.

Farm Show. (1981). "Lightning Weeder" Kills Weeds With Electricity. *Farm Show, Volume 05 Issue 02, Page 21*.

HSE (2009) Infoline (Tel: 0845 345 0055) <http://www.hse.gov.uk/agriculture/index.htm>

Kaufman. K.R., Schaffner. L.W. (1982). Energy and Economics of electrical weed control. *Trans. ASAE*, 25(2):297-300.

Mathiaassen. S.K., Bak. T., Christensen. S., Kudsk. P. (2006) The effect of Laser Treatment as a Weed Control Method. *Biosystems Engineering* 95(4):497-505.

US3919806 (1975). Method and apparatus for using electrical current to destroy grasses and weeds. United States Patent http://ep.espacenet.com/numberSearch?locale=en_EP

US4094095 (1978). Method and apparatus for using electrical current to destroy weeds in and around crops. United States Patent http://ep.espacenet.com/numberSearch?locale=en_EP

Vigneault. C. (2002). Weed electrocution. *Encyclopaedia of pest management*, Marcel Dekker Inc, 896-898.

Vigneault, C., Benoit, D.L., McLaughlin, N.B., (1990). Energy aspect of weed electrocution. *Rev. Weed Sci.* 5:15-26.

Vigoureux. A. (1981). Results of trials carried out in Belgium in 1980 about killing weed beets by electric discharge. *Meded. Fac. Landbouww. Ryksuniv. Gent.* 46:163-172.